

No. of plungers	5
Maximum rated speed	600 rpm
Stroke length.....	2.25 in. 57.15 mm
Maximum rated power.....	100 HP 74.5 KW
Maximum rod load	5280 lb. 23.4 kN
Weight	720 lbs.

ENGLISH UNITS

SC-80H

PLUNGER SIZE IN.	STUFFING BOX BORE IN.	MAX PSI	*GALLON PER/REV.	200 RPM US GPM	300 RPM US GPM	400 RPM US GPM	500 RPM US GPM	600 RPM US GPM
1.375	2.250	3558	0.0723	14.5	21.7	28.9	36.2	43.4
1.250	2.250	4306	0.0598	12.0	17.9	23.9	29.9	35.9
1.125	1.750	5316	0.0484	9.7	14.5	19.4	24.2	29.0
1.000	1.750	6500	0.0383	7.7	11.5	15.3	19.1	23.0
<i>HP REQUIRED @ RPM**</i>				33.5	50.1	66.7	83.4	100.0

METRIC UNITS

SC-80H

PLUNGER SIZE MM.	STUFFING BOX BORE MM.	MAX PRESS. BAR	*LITER PER/REV.	200 RPM LPM	300 RPM LPM	400 RPM LPM	500 RPM LPM	600 RPM LPM
34.9	57.1	245.4	0.2737	54.7	82.1	109.5	136.9	164.2
31.7	57.1	296.9	0.2264	45.3	67.9	90.6	113.2	135.8
28.5	44.4	366.6	0.1832	36.6	55.0	73.3	91.6	109.9
25.4	44.4	448.3	0.1450	29.0	43.5	58.0	72.5	87.0
<i>KW REQUIRED @ RPM**</i>				24.9	37.4	49.7	62.2	74.6

*Displacement based on 100% Volumetric Efficiency

**Power based on 90% Mechanical Efficiency

$$IHP = \frac{USGPM \times (\text{Discharge psig} - 1/2 \text{ Suction psig})}{1542}$$

$$IKW = \frac{M^3/HR \times (\text{Discharge Bar} - 1/2 \text{ Suction Bar})}{17.99}$$

$$PUMP \text{ RPM} = \frac{USGPM \text{ Desired}}{USGPM \text{ per Revolution of Selected Plunger}}$$

$$PUMP \text{ RPM} = \frac{M^3/HR \text{ Desired}}{M^3 \text{ per Revolution of Selected}}$$

SC-80H Quintuplex Pump

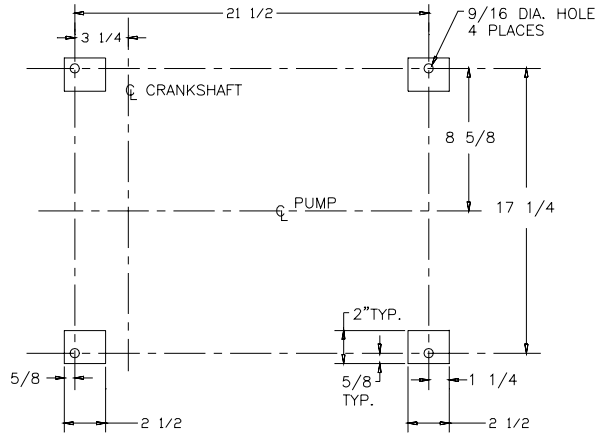
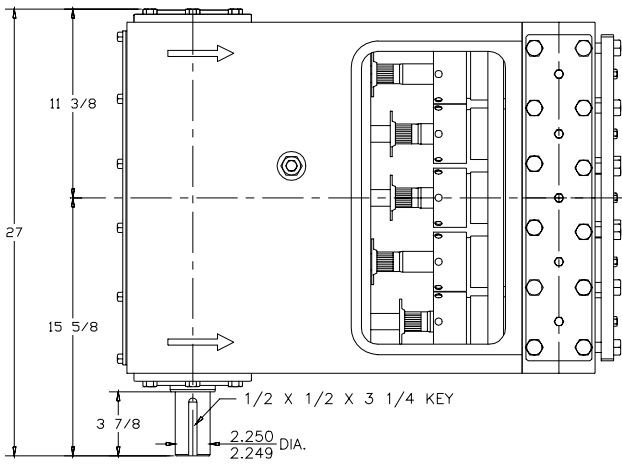

FOUNDATION PLAN

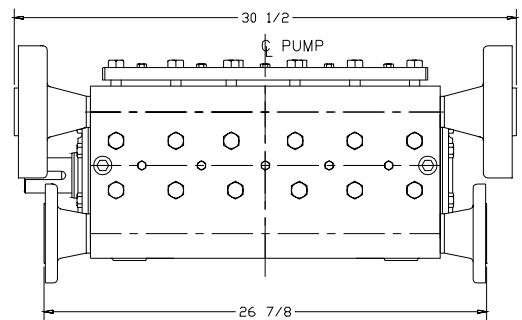
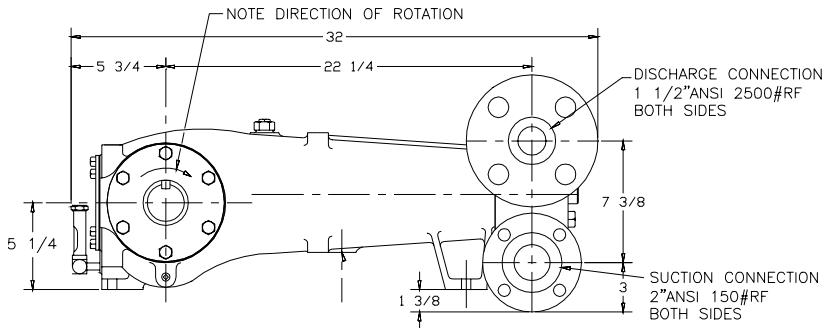
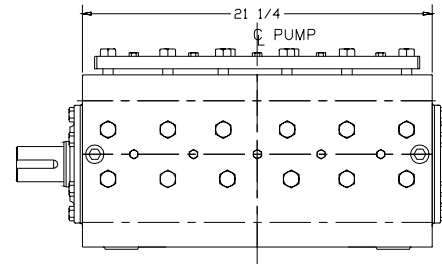
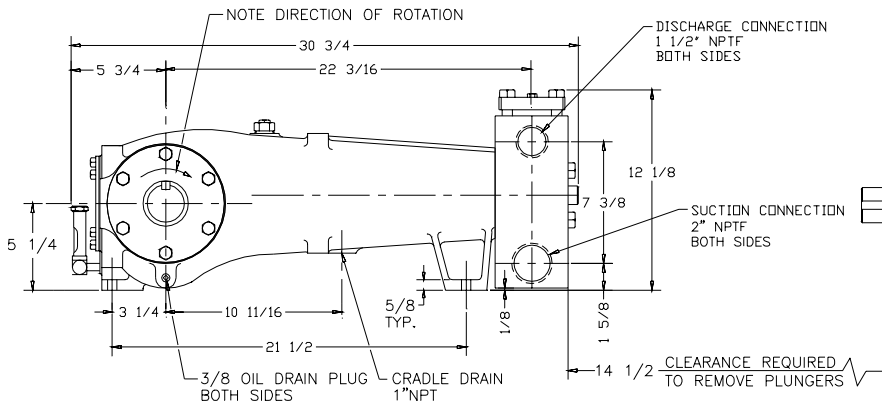

ENGINEERING DATA

SC-80H Quintuplex Pump

POWER END ENGINEERING DATA

Max. Input Power @ Speed	100 HP @ 600 rpm
Rated Continuous Plunger Load	5,280 lb.
Max. Rated Continuous Speed	600 rpm
Normal Continuous Speed Range	150 to 500 rpm
Minimum Speed	100 rpm
Oil Capacity	8 U.S. Qrts
Power End Oiling System	Splash & Scoop
Power Frame, One-Piece	Cast Iron
Crosshead, Full Cylindrical	Cast Iron
Crosshead, Dia. x Length	3 1/4 x 3 5/8 in.
Crankshaft	Ductile Iron
Crankshaft Diameters:	
At Tapered Roller Bearings	3.15 in.
At Center Bearings	4.91 in.
At Crankpin Bearings, Dia. x Length	2 1/4 x 1 5/8 in.
Crosshead (Wrist) Pin, Case-Hardened and Ground	AISI 8620
Main Bearings, Tapered Roller	Timken
Center Bearings, Two, Precision	Steel Backed, Babbitt-Lined
Crankpin Bearings, Precision Automotive	Steel Backed, Babbitt-Lined
Extension (Pony) Rod, Integral w/ Plungers	316 S.S.
Connecting Rod, Automotive Type	Ductile Iron
Average Crosshead Speed @ 600 rpm	169 fpm
Minimum Life Expectancy, Main Bearings, L ₁₀	75,000+ hr.

LIQUID END ENGINEERING DATA

Max. Continuous Working Pressure	6,500 psi
Hydrostatic Test	9,750 psi
Available Liquid End Materials, A.S.T.M.	
Stainless Steel Block	15-5PH
Carbon Steel Block	4140
Plunger Type "Rokide" (Chromium Oxide-Coated)	316 S.S.
Stuffing Boxes, Field-Removable and Replaceable	
Stainless Steel	17-4PH
Carbon Steel	1020
Packing Types Available	
Spring-loaded, Braided Teflon & Kevlar	Style 140
Spring-loaded, cup-type	Style 120X
Valve Cover and Cyl. Head Plugs	416 or 316 S.S.
Retainer Plates, Ductile Iron, A.S.T.M.	A536 80-55-06
Seals, Stuffing Boxes, Valve Covers, Cyl. Heads	Buna-N
Valve Types	
Disc, Hardened and Lapped	17-4 PH S.S.
Optional, Abrasion Resistant	17-4 PH S.S.
Valve Spring material	Inconel
Valve Seat, Liquid Passage Areas	1.4 sq.in.
Avg. Liquid Velocity @ 600 rpm	
thru Valves	2.1 fps
thru Suction Manifold	1.9 fps
thru Discharge Manifold	3.8 fps

All drawings and specifications subject to change without notice.

SC-80H Quintuplex Pump

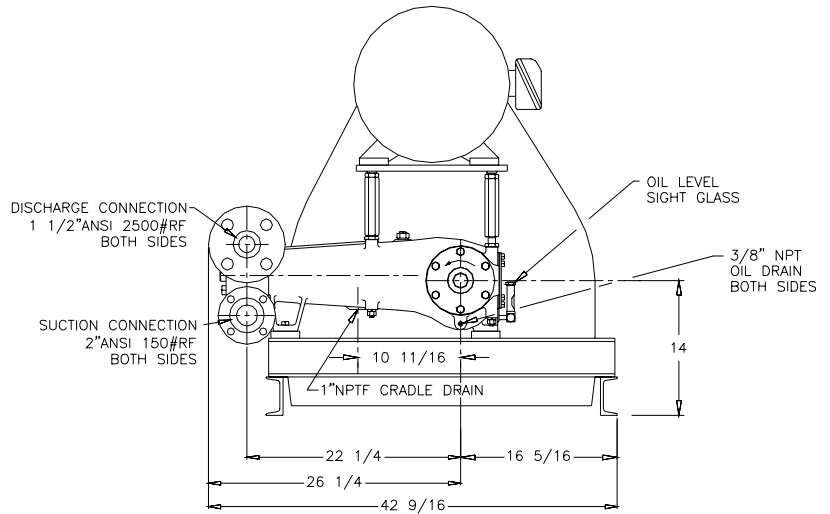
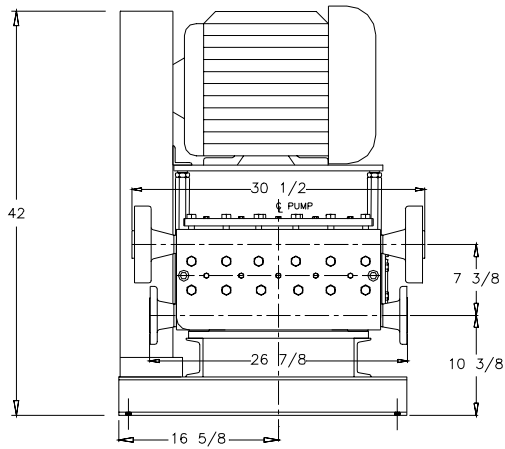
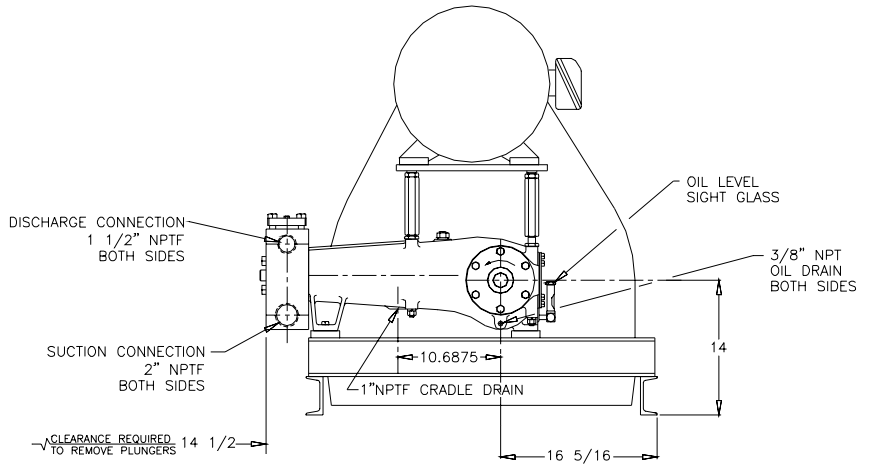
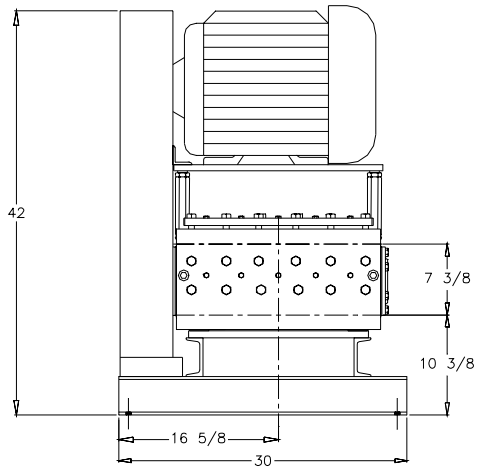

1101 Myers Parkway
Ashland, Ohio 4408-1969
419/289-1144
FAX: 419/289-6658
www.myers-aplex.com
myers-aplex@femyers.com

269 Trillium Drive
Kitchener, Ontario N2G 4W5
519/748-5470
FAX: 519/748-2553