



STELLAR® XCHANGE HOOKLIFT TECHNICAL SPECIFICATION GUIDE

# XCHANGE

Single Pivot Hooklift



*Our People. Our Products.*

# STELLAR® XCHANGE SINGLE PIVOT HOOKLIFT HOIST

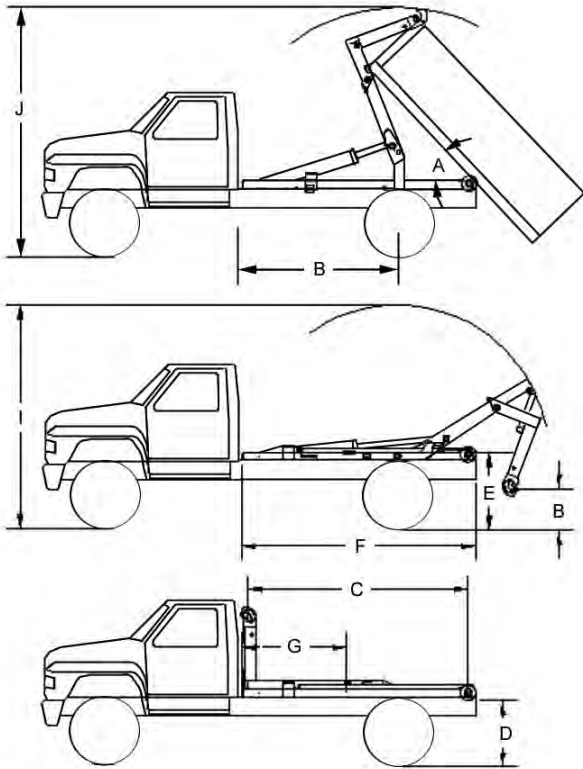

## ■ SPECIFICATION INFORMATION

- Will accommodate bodies from 10-feet up to 17.5-feet long on a 36-inch high frame truck. Longer bodies will have reduced dumping capabilities.
- Transmission-mounted PTO and hydraulic pump required to power the hooklift.
- Standard in-cab manual controls which allow for precise metering of the manual hydraulic valve. Solenoid-activated hydraulic control valve with electric remote control pendant is optional.
- Ten (10) gallon frame-mounted oil reservoir.
- Operating pressure is 4,200 psi.
- Hydraulic flow required is 10-gallons (15-gallons for 20,000 lb. capacity) per minute.
- Hydraulic locks to prevent cylinder collapse in case of hose failure.
- Hook latch to prevent body from becoming detached prematurely.
- Mechanical rear body tie-down latches.
- Permanently lubricated and greaseless bushings used throughout.
- Stainless steel pins used throughout.
- All weldments painted with two-part polyurethane enamel.

<b>Item Description</b>	<b>84-12-9</b>	<b>120-15-9</b>	<b>84-12-13</b>	<b>120-15-13</b>	<b>120-16-13</b>	<b>120-15-20</b>	<b>138-18-20</b>	<b>138-18-20/SPL**</b>
Lifting / Dump Cap.	9,000 lb. (4,082 kg)	9,000 lb. (4,082 kg)	13,000 lb. (5,897 kg)	13,000 lb. (5,897 kg)	13,000 lb. (5,897 kg)	20,000 lb. (9,072 kg)	20,000 lb. (9,072 kg)	20,000 lb. (9,072 kg)
Dump Angle	57°	56°	58°	56°	49°	59°	66°	51°
Effective Length	115" (2,921 mm)	140" (3,556 mm)	115" (2,921 mm)	140" (3,556 mm)	151" (3,835 mm)	135" (3,429 mm)	153" (3,886 mm)	174" (4,420 mm)
Cab to Axle	84"-96" (2,134-2,438 mm)	108"-120" (2,743-3,048 mm)	84"-96" (2,134- 2,438 mm)	108"-120" (2,743- 3,048 mm)	120"-130" (3,048- 3,302 mm)	108"-120" (2,743- 3,048 mm)	139" (3,531 mm)	138" (3,505 mm)
Shipping Weight	1,350 lb. (612 kg)	1,500 lb. (680 kg)	1,400 lb. (635 kg)	1,500 lb. (680 kg)	1,550 lb. (703 kg)	2,050 lb. (930 kg)	2,450 lb. (1,111 kg)	2,475 lb. (1,123 kg)
Body Lengths	10'-12.5' (3,048-3,810 mm)	12'-14.5' (3,658-4,420 mm)	10'-12.5' (3,048-3,810 mm)	12'-14.5' (3,658-4,420 mm)	13'-15.5' (3,962-4,724 mm)	11.5'-14' (3,505-4,267 mm)	13'-15.5' (3,962-4,724 mm)	14.5'-17.5' (4,420-5,334 mm)
Hook Height	35.63" (905 mm)	35.63" (905 mm)	35.63" (905 mm)	35.63" (905 mm)	35.63" (905 mm)	54" (1,372 mm)	54" (1,372 mm)	54" (1,372 mm)
Min. GVWR	14,000 lb. (6,350 kg)	14,000 lb. (6,350 kg)	19,000 lb. (8,618 kg)	19,000 lb. (8,618 kg)	19,000 lb. (8,618 kg)	25,000 lb. (11,340 kg)	25,000 lb. (11,340 kg)	25,000 lb. (11,340 kg)

\* Dump angles are for shortest length bodies.  
Longer bodies will have smaller dump angles.

\*\*Single Pivot Long Version

## ■ KEY FEATURES

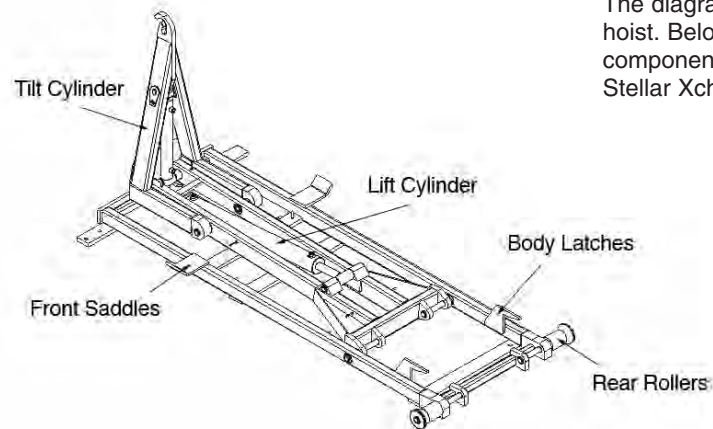

The diagram shows a typical Stellar Xchange hoist. Below is a detailed explanation of these components which are an integral part of every Stellar Xchange hydraulic Hooklift hoist.

- Lift Cylinder:** The lift cylinder on a Stellar Xchange not only lifts the body onto the truck, but it also provides the dumping movement. All Stellar Xchange lift cylinders feature integral pilot-operated counterbalance valves which provide for optimum meter-ability and protection against sudden movement in the case of hose failure.
- Front Saddles:** Front saddles provide a place for the body to rest while the truck is in motion.
- Body Latch:** The body latch is also referred to as the rear tie-down. Standard on Stellar Xchange hoist are the rearward facing hooks that interface with a horizontal steel pocket or tab. As the body is pulled forward into the final storage position prior to transporting, the tabs will pull tight in the hook pockets. Hydraulic activated rear tie-downs are optional on larger Stellar Xchange hoist.
- Rear Rollers:** With the unique Stellar Xchange design, bodies are loaded and unloaded with a “lift and roll” movement. While unloading a body, the tilt section will lift the front of the body and roll it back. The tilt cylinder will continue rolling the body until the rear of the body contacts the ground.
- Tilt Cylinder:** The tilt cylinder operates the tilt section of the Stellar Xchange. This cylinder features a pilot-operated counterbalance valve on both extend and retract sides. The tilt section is a key component of the Stellar Xchange. The tilt section provides the selection of dump or load/off-load. With Stellar’s unique twin post design, line-of-sight visibility of the hook is available from the truck cab.

## ■ Stellar® Hooklift Reference Chart\*

Model	Lift Capacity	Body Lengths	Cab-To-Axle (Trunnion)	Hook Height
<b>Flex36 60-8</b>	Up to 9,000 (4,082 kg)	8-9 (2,438-2,743 mm)	60 (1,524 mm)	35.63 (905 mm)
<b>Flex36 84-10</b>	16,000 (7,257 kg)	10-12 (3,048-3,658 mm)	84-96 (2,134-2,438 mm)	35.63 (905 mm)
<b>Flex36 108-12</b>	16,000 (7,257 kg)	12-14 (3,658-4,267 mm)	108-120 (2,743-3,048 mm)	35.63 (905 mm)
<b>Flex36 120-14</b>	16,000 (7,257 kg)	13-15 (3,962-4,572 mm)	120-130 (3,048-3,302 mm)	35.63 (905 mm)
<b>108-12-20/36</b>	20,000 (9,072 kg)	12-13.5 (3,658-4,115 mm)	102-108 (2,591-2,743 mm)	35.63 (905 mm)
<b>108-11-20</b>	20,000 (9,072 kg)	11-13.5 (3,353-4,115 mm)	102-108 (2,591-2,743 mm)	54 (1,372 mm)
<b>120-16-20</b>	20,000 (9,072 kg)	12.5-15 (3,810-4,572 mm)	114-130 (2,896-3,302 mm)	54 (1,372 mm)
<b>138-18-20</b>	20,000 (9,072 kg)	14.5-17 (4,420-5,182 mm)	130-144 (3,302-3,658 mm)	54 (1,372 mm)
<b>168-20-20</b>	20,000 (9,072 kg)	16.5-19 (5,029-5,791 mm)	168-180 (4,267-4,572 mm)	61.75 (1,568 mm)
<b>190-24-20</b>	20,000 (9,072 kg)	18.5-21.5 (5,639-6,553 mm)	190-200 (4,826-5,080 mm)	61.75 (1,568 mm)
<b>96-10-24</b>	24,000 (10,886 kg)	10-12.5 (3,048-3,810 mm)	84-102 (2,134-2,591 mm)	54 (1,372 mm)
<b>108-14-32</b>	32,000 (14,515 kg)	12-15 (3,658-4,572 mm)	102-108 C.T. (2,590-2,743 mm)	61.75 (1,568 mm)
<b>138-18-32</b>	32,000 (14,515 kg)	15-17.5 (4,572-5,334 mm)	130-144 C.T. (3,302-3,658 mm)	61.75 (1,568 mm)
<b>174-20-32</b>	32,000 (14,515 kg)	17.5-20 (5,334-6,096 mm)	160-174 C.T. (4,064-4,420 mm)	61.75 (1,568 mm)
<b>190-24-32</b>	32,000 (14,515 kg)	19-21.5 (5,791-6,553 mm)	174-190 C.T. (4,420-4,826 mm)	61.75 (1,568 mm)
<b>138-18-34</b>	34,000 (15,422 kg)	15-17.5 (4,572-5,334 mm)	130-144 C.T. (3,302-3,658 mm)	54 (1,372 mm)
<b>108-14-40</b>	40,000 (18,144 kg)	12-15 (3,658-4,572 mm)	102-108 C.T. (2,591-2,743 mm)	61.75 (1,568 mm)
<b>138-18-40</b>	40,000 (18,144 kg)	15-17.5 (4,572-5,334 mm)	130-144 C.T. (3,302-3,658 mm)	61.75 (1,568 mm)
<b>174-20-40</b>	40,000 (18,144 kg)	17.5-20 (5,334-6,096 mm)	160-174 C.T. (4,064-4,420 mm)	61.75 (1,568 mm)
<b>190-24-40</b>	40,000 (18,144 kg)	19-21.5 (5,791-6,553 mm)	174-190 C.T. (4,420-4,826 mm)	61.75 (1,568 mm)
<b>138-18-52</b>	52,000 (23,587 kg)	15-17.5 (4,572-5,334 mm)	138-144 C.T. (3,505-3,658 mm)	61.75 (1,568 mm)
<b>174-20-52</b>	52,000 (23,587 kg)	17.5-20 (5,334-6,096 mm)	160-174 C.T. (4,064-4,420 mm)	61.75 (1,568 mm)
<b>190-24-52</b>	52,000 (23,587 kg)	19-21.5 (5,791-6,553 mm)	174-190 C.T. (4,420-4,826 mm)	61.75 (1,568 mm)
<b>138-18-65</b>	65,000 (29,484 kg)	15-17.5 (4,572-5,334 mm)	138-144 C.T. (3,505-3,658 mm)	61.75 (1,568 mm)
<b>174-20-65</b>	65,000 (29,484 kg)	17-20 (5,182-6,096 mm)	160-174 C.T. (4,064-4,420 mm)	61.75 (1,568 mm)
<b>190-24-65</b>	65,000 (29,484 kg)	19-21.5 (5,791-6,553 mm)	174-190 C.T. (4,420-4,826 mm)	61.75 (1,568 mm)

## ■ Stellar® Slider (Sliding Jib Hooklift)

<b>Slider20 (54")</b>	20,000 (9,071 kg)	13-18 (3,962-5,486 mm)	138-156 (3,505-3,962 mm)	54 (1,372 mm)
<b>Slider20 (61.75")</b>	20,000 (9,071 kg)	13-18 (3,962-5,486 mm)	138-156 (3,505-3,962 mm)	61.75 (1,568 mm)
<b>Slider34 (54")</b>	28,000 (12,001 kg)	14-20 (4,267-6,096 mm)	160-174 C.T. (4,064-4,420 mm)	54 (1,372 mm)
<b>Slider34 (61.75")</b>	34,000 (15,422 kg)	14-20 (4,267-6,096 mm)	160-174 C.T. (4,064-4,420 mm)	61.75 (1,568 mm)
<b>Slider65 (54")</b>	52,000 (23,587 kg)	16-22 (4,877-6,706 mm)	180-190 C.T. (4,572-4,826mm)	54 (1,372 mm)
<b>Slider65 (61.75")</b>	65,000 (29,484 kg)	16-22 (4,877-6,706 mm)	180-190 C.T. (4,572-4,826mm)	61.75 (1,568 mm)

## ■ Stellar® Xchange (Single Pivot Hooklift)

<b>84-12-9</b>	9,000 (4,082 kg)	10-12.5 (3,048-3,810 mm)	84-96 (2,134-2,438 mm)	35.63 (905 mm)
<b>120-15-9</b>	9,000 (4,082 kg)	12-14.5 (3,658-4,420 mm)	108-120 (2,743-3,048 mm)	35.63 (905 mm)
<b>84-12-13</b>	13,000 (5,897 kg)	10-12.5 (3,048-3,810 mm)	84-96 (2,134-2,438 mm)	35.63 (905 mm)
<b>120-15-13</b>	13,000 (5,897 kg)	12-14.5 (3,658-4,420 mm)	108-120 (2,743-3,048 mm)	35.63 (905 mm)
<b>120-16-13</b>	13,000 (5,897 kg)	13-15.5 (3,962-4,724 mm)	120-130 (3,048- 3,302 mm)	35.63 (905 mm)
<b>120-15-20</b>	20,000 (9,072 kg)	11.5-14 (3,505-4,267 mm)	108-120 (2,743-3,048 mm)	54 (1,372 mm)
<b>138-18-20</b>	20,000 (9,072 kg)	13-15.5 (3,962-4,724 mm)	139 (3,531 mm)	54 (1,372 mm)
<b>138-18-20/SPL</b>	20,000 (9,072 kg)	14.5-17.5 (4,420-5,334 mm)	1389 (3,505 mm)	54 (1,372 mm)

Your local dealer:



*Our People. Our Products.*

190 State Street  
P.O. Box 169  
Garner, IA 50438  
Telephone: (641) 923-3741 • (800) 321-3741  
Fax: (641) 923-2812

\* This data is for reference purposes only, and is not intended to replace a properly calculated weight distribution.

Government specifications available.

\* All specifications are subject to change without notification.

For the most up to date version of this brochure, please visit [www.stellarindustries.com](http://www.stellarindustries.com).

Internet: [www.stellarindustries.com](http://www.stellarindustries.com)  
Email: [sales@stellarindustries.com](mailto:sales@stellarindustries.com)

An Employee Owned Company.  
Copyright © 2008 Stellar Industries, Inc.