



STELLAR® SLIDER HOOKLIFT TECHNICAL SPECIFICATION GUIDE

SLIDER

Adjustable Sliding Jib Hooklift Hoist



Our People. Our Products.

STELLAR® SLIDER ADJUSTABLE JIB HOOKLIFT HOIST

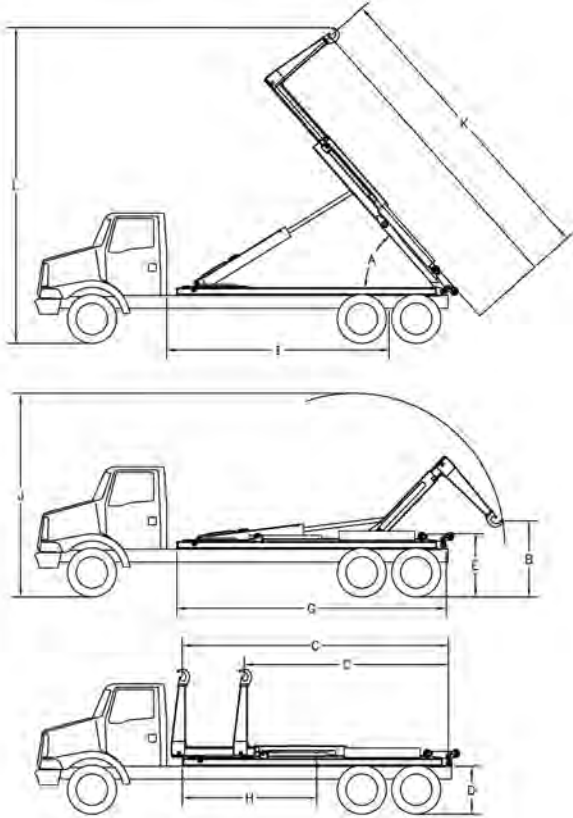

■ SPECIFICATION INFORMATION

- Transmission-mounted PTO and hydraulic pump required to power the hooklift.
- Standard in-cab manual controls which allow for precise metering of the manual hydraulic valve. Solenoid-activated hydraulic control valve with electric remote control pendant is optional.
- Ten (10) gallon frame-mounted oil tank.
- Hydraulic flow required is 20-gallons (15-gallons for Slider20) per minute.
- Patented dump/load interface as featured on most Stellar Hooklifts.
- Hydraulic locks to prevent cylinder collapse in case of hose failure.
- Hook latch to prevent body from becoming detached prematurely.
- Slide through rear body tie-down latches.
- Proximity switch to prevent front jib movement when the dump frame is raised.
- Permanently lubricated and greaseless bushings used throughout.
- Stainless steel pins used throughout.
- All weldments painted with two-part polyurethane enamel.

Item Description	Slider20 - 54"	Slider20 - 61.75"	Slider34 - 54"	Slider34 - 61.75"	Slider65 - 54"	Slider65 - 61.75"
Lifting Capacity	20,000 lb. (9,071 kg)	20,000 lb. (9,071 kg)	28,000 lb. (12,001 kg)	34,000 lb. (15,422 kg)	52,000 lb. (23,587 kg)	65,000 lb. (29,484 kg)
Dumping Capacity	20,000 lb. (9,071 kg)	20,000 lb. (9,071 kg)	34,000 lb. (15,422 kg)	34,000 lb. (15,422 kg)	65,000 lb. (29,484kg)	65,000 lb. (29,484kg)
Dump Angle	55°	55°	50°	50°	50°	50°
Effective Length	143"-185" (3,632-4,699 mm)	143"-185" (3,632-4,699 mm)	168"-208" (4,267-5,283 mm)	168"-208" (4,267-5,283 mm)	193"-224" (4,902-5,690 mm)	193"-224" (4,902-5,690 mm)
Cab to Axle	138"-156" (3,505-3,962 mm)	138"-156" (3,505-3,962 mm)	180"-188" (4,572-4,775 mm)	180"-188" (4,572-4,775 mm)	180" optimum (4,572mm)	180" optimum (4,572mm)
Cab to Trunnion	138"-156" (3,505-3,962 mm)	138"-156" (3,505-3,962 mm)	160"-174" (4,064-4,420 mm)	160"-174" (4,064-4,420 mm)	170" minimum (4,318mm)	170" minimum (4,318mm)
					190" with tarper (4,826mm)	190" with tarper (4,826mm)
Shipping Weight	3,500 lb. (1,588 kg)	3,500 lb. (1,588 kg)	4,650 lb. (2,109 kg)	4,650 lb. (2,109 kg)	6,600 lb. (2,994 kg)	6,600 lb. (2,994 kg)
Rec. Body Lengths	13' - 18' (3,962-5,486 mm)	13' - 18' (3,962-5,486 mm)	14' - 20' (4,267-6,096 mm)	14' - 20' (4,267-6,096 mm)	16' - 22' (4,877-6,706 mm)	16' - 22' (4,877-6,706 mm)
Hook Height	54" (1,372 mm)	61.75" (1,568 mm)	54" (1,372 mm)	61.75" (1,568 mm)	54" (1,372 mm)	61.75" (1,568 mm)
Min. Truck GVWR	25,000 lb. (11,340 kg)	25,000 lb. (11,340 kg)	32,000 lb. (14,515 kg)	32,000 lb. (14,515 kg)	54,000 lb. (24,494 kg)	54,000 lb. (24,494 kg)

■ KEY FEATURES

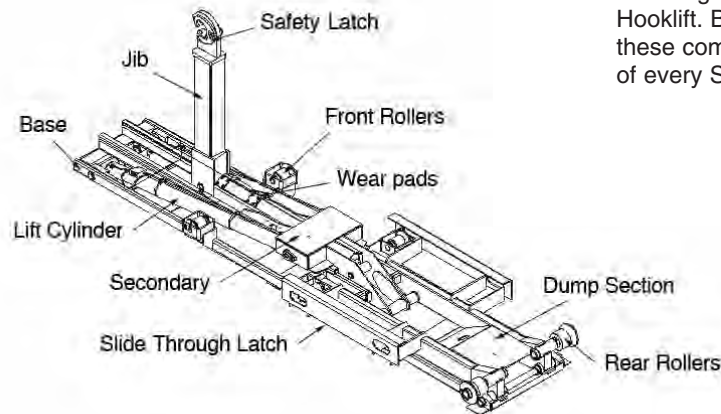

The diagram shows a typical Stellar Slider Hooklift. Below is a detailed explanation of these components which are an integral part of every Stellar Slider hydraulic Hooklift hoist.

- Base Section:** The base section of a Stellar Slider may also be called a sub-frame. All Stellar Slider Hooklifts are tied together in one common framework. This base section not only adds strength to the hoist, but it places less stress concentration on the truck chassis than hooklifts without a common base. The base section provides for a simple installation on most truck chassis.
- Slide Through Latch:** The slide through latch allows for the securement of several lengths of containers.
- Jib:** The sliding jib allows for a wide range of container lengths and a means to control the trucks weight distribution.
- Wear Pads:** The wear pads within the sliding jib provide a replaceable surface to ensure a long life for the metal components.
- Dump Section:** This component of the Stellar Slider pivots at the rear of the hoist when interacting with the patented tabs on the jib section. The rear body latches are attached to this component on most models. This allows the body to remain in the latches when dumping.
- Front Rollers:** Provide a supportive surface for the body while sliding the body forward. This support then takes weight off the jib.
- Lift Cylinder:** The lift cylinder on a Stellar Slider not only lifts the body onto the truck, but it also provides the dumping movement. All Stellar Slider lift cylinders feature dual pilot-operated counterbalance valves which provide for optimum meter-ability and protection against sudden movement in the case of hose failure.
- Rear Rollers:** With the unique Stellar Slider design, bodies are loaded and unloaded with a “lift and roll” movement.
- Secondary:** The secondary section acts as the main pivoting member for loading/ off-loading bodies. This component ties the jib, dump and base sections together into one cohesive unit.

■ Stellar® Hooklift Reference Chart*

Model	Lift Capacity	Body Lengths	Cab-To-Axle (Trunnion)	Hook Height
Flex36 60-8	Up to 9,000 (4,082 kg)	8-9 (2,438-2,743 mm)	60 (1,524 mm)	35.63 (905 mm)
Flex36 84-10	16,000 (7,257 kg)	10-12 (3,048-3,658 mm)	84-96 (2,134-2,438 mm)	35.63 (905 mm)
Flex36 108-12	16,000 (7,257 kg)	12-14 (3,658-4,267 mm)	108-120 (2,743-3,048 mm)	35.63 (905 mm)
Flex36 120-14	16,000 (7,257 kg)	13-15 (3,962-4,572 mm)	120-130 (3,048-3,302 mm)	35.63 (905 mm)
108-12-20/36	20,000 (9,072 kg)	12-13.5 (3,658-4,115 mm)	102-108 (2,591-2,743 mm)	35.63 (905 mm)
108-11-20	20,000 (9,072 kg)	11-13.5 (3,353-4,115 mm)	102-108 (2,591-2,743 mm)	54 (1,372 mm)
120-16-20	20,000 (9,072 kg)	12.5-15 (3,810-4,572 mm)	114-130 (2,896-3,302 mm)	54 (1,372 mm)
138-18-20	20,000 (9,072 kg)	14.5-17 (4,420-5,182 mm)	130-144 (3,302-3,658 mm)	54 (1,372 mm)
168-20-20	20,000 (9,072 kg)	16.5-19 (5,029-5,791 mm)	168-180 (4,267-4,572 mm)	61.75 (1,568 mm)
190-24-20	20,000 (9,072 kg)	18.5-21.5 (5,639-6,553 mm)	190-200 (4,826-5,080 mm)	61.75 (1,568 mm)
96-10-24	24,000 (10,886 kg)	10-12.5 (3,048-3,810 mm)	84-102 (2,134-2,591 mm)	54 (1,372 mm)
108-14-32	32,000 (14,515 kg)	12-15 (3,658-4,572 mm)	102-108 C.T. (2,590-2,743 mm)	61.75 (1,568 mm)
138-18-32	32,000 (14,515 kg)	15-17.5 (4,572-5,334 mm)	130-144 C.T. (3,302-3,658 mm)	61.75 (1,568 mm)
174-20-32	32,000 (14,515 kg)	17.5-20 (5,334-6,096 mm)	160-174 C.T. (4,064-4,420 mm)	61.75 (1,568 mm)
190-24-32	32,000 (14,515 kg)	19-21.5 (5,791-6,553 mm)	174-190 C.T. (4,420-4,826 mm)	61.75 (1,568 mm)
138-18-34	34,000 (15,422 kg)	15-17.5 (4,572-5,334 mm)	130-144 C.T. (3,302-3,658 mm)	54 (1,372 mm)
108-14-40	40,000 (18,144 kg)	12-15 (3,658-4,572 mm)	102-108 C.T. (2,591-2,743 mm)	61.75 (1,568 mm)
138-18-40	40,000 (18,144 kg)	15-17.5 (4,572-5,334 mm)	130-144 C.T. (3,302-3,658 mm)	61.75 (1,568 mm)
174-20-40	40,000 (18,144 kg)	17.5-20 (5,334-6,096 mm)	160-174 C.T. (4,064-4,420 mm)	61.75 (1,568 mm)
190-24-40	40,000 (18,144 kg)	19-21.5 (5,791-6,553 mm)	174-190 C.T. (4,420-4,826 mm)	61.75 (1,568 mm)
138-18-52	52,000 (23,587 kg)	15-17.5 (4,572-5,334 mm)	138-144 C.T. (3,505-3,658 mm)	61.75 (1,568 mm)
174-20-52	52,000 (23,587 kg)	17.5-20 (5,334-6,096 mm)	160-174 C.T. (4,064-4,420 mm)	61.75 (1,568 mm)
190-24-52	52,000 (23,587 kg)	19-21.5 (5,791-6,553 mm)	174-190 C.T. (4,420-4,826 mm)	61.75 (1,568 mm)
138-18-65	65,000 (29,484 kg)	15-17.5 (4,572-5,334 mm)	138-144 C.T. (3,505-3,658 mm)	61.75 (1,568 mm)
174-20-65	65,000 (29,484 kg)	17-20 (5,182-6,096 mm)	160-174 C.T. (4,064-4,420 mm)	61.75 (1,568 mm)
190-24-65	65,000 (29,484 kg)	19-21.5 (5,791-6,553 mm)	174-190 C.T. (4,420-4,826 mm)	61.75 (1,568 mm)

■ Stellar® Slider (Sliding Jib Hooklift)

Slider20 (54")	20,000 (9,071 kg)	13-18 (3,962-5,486 mm)	138-156 (3,505-3,962 mm)	54 (1,372 mm)
Slider20 (61.75")	20,000 (9,071 kg)	13-18 (3,962-5,486 mm)	138-156 (3,505-3,962 mm)	61.75 (1,568 mm)
Slider34 (54")	28,000 (12,001 kg)	14-20 (4,267-6,096 mm)	160-174 C.T. (4,064-4,420 mm)	54 (1,372 mm)
Slider34 (61.75")	34,000 (15,422 kg)	14-20 (4,267-6,096 mm)	160-174 C.T. (4,064-4,420 mm)	61.75 (1,568 mm)
Slider65 (54")	52,000 (23,587 kg)	16-22 (4,877-6,706 mm)	180-190 C.T. (4,572-4,826mm)	54 (1,372 mm)
Slider65 (61.75")	65,000 (29,484 kg)	16-22 (4,877-6,706 mm)	180-190 C.T. (4,572-4,826mm)	61.75 (1,568 mm)

■ Stellar® Xchange (Single Pivot Hooklift)

84-12-9	9,000 (4,082 kg)	10-12.5 (3,048-3,810 mm)	84-96 (2,134-2,438 mm)	35.63 (905 mm)
120-15-9	9,000 (4,082 kg)	12-14.5 (3,658-4,420 mm)	108-120 (2,743-3,048 mm)	35.63 (905 mm)
84-12-13	13,000 (5,897 kg)	10-12.5 (3,048-3,810 mm)	84-96 (2,134-2,438 mm)	35.63 (905 mm)
120-15-13	13,000 (5,897 kg)	12-14.5 (3,658-4,420 mm)	108-120 (2,743-3,048 mm)	35.63 (905 mm)
120-16-13	13,000 (5,897 kg)	13-15.5 (3,962-4,724 mm)	120-130 (3,048- 3,302 mm)	35.63 (905 mm)
120-15-20	20,000 (9,072 kg)	11.5-14 (3,505-4,267 mm)	108-120 (2,743-3,048 mm)	54 (1,372 mm)
138-18-20	20,000 (9,072 kg)	13-15.5 (3,962-4,724 mm)	139 (3,531 mm)	54 (1,372 mm)
138-18-20/SPL	20,000 (9,072 kg)	14.5-17.5 (4,420-5,334 mm)	1389 (3,505 mm)	54 (1,372 mm)

Your local dealer:



Our People. Our Products.

190 State Street
P.O. Box 169
Garner, IA 50438
Telephone: (641) 923-3741 • (800) 321-3741
Fax: (641) 923-2812

* This data is for reference purposes only, and is not intended to replace a properly calculated weight distribution.

Government specifications available.

* All specifications are subject to change without notification.

For the most up to date version of this brochure, please visit www.stellarindustries.com.

Internet: www.stellarindustries.com
Email: sales@stellarindustries.com

An Employee Owned Company.
Copyright © 2008 Stellar Industries, Inc.